

**UBND HUYỆN CỬ CHI
TRƯỜNG TRUNG CẤP NGHỀ CỬ CHI**

**GIÁO TRÌNH
MÔN HỌC/MÔ ĐUN: ANH VĂN CHUYÊN NGÀNH
NGHỀ: K THU T S A CH A VÀ L P RÁP MÁY TÍNH
TRÌNH ĐỘ: TRUNG CẤP NGHỀ**

*Ban hành kèm theo Quyết định số: 48/QĐ-TCN, ngày 04 tháng 10 năm 2021
của Hiệu trưởng Trường Trung cấp nghề Cử Chi*

Tp. Hồ Chí Minh, năm 2021

CONTENTS

Unit 1	Personal computing.....page 4
Unit 2	Portable computerspage 9
Unit 3	Computer applicationspage 12
Unit 4	Computer essentialspage 16
Unit 5	Input/output devicespage 22
Unit 6	Inside the systempage 26
Unit 7	Operating systempage 32
Unit 8	Computer networkspage 36
Unit 9	Computer virusespage 40
Unit 10	Word processing Page 44
Unit 11	Faces of the Internet Page 52
Unit 12	New technologies Page 56
Unit 13	Spreadsheet Page 55

Unit 1 Computer applications

A Computers have many applications in a great variety of fields. Look at these photographs of different situations and match them with texts 1 to 4 below.



a

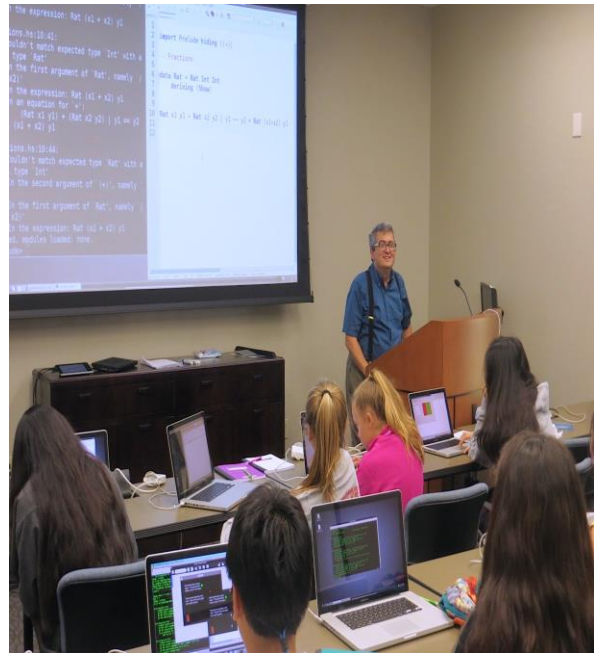

b



c



d

b. execute (do)

g. self-acting, mechanical

c. connected with money

h. screen

d. keep (save)

i. powerful computer usually
connected to a network

e. massive

j. program used for text manipulation

E Mary and Jim are talking about buying the first computer. Listen to the conversation and decide if the following are true or false.

Statements	True	False
1. Mary wants to buy a computer		
2. Jim thinks Compaq computer will be suitable for him		
3. Gateway computer is very expensive in America		
4. Mary knows nothing about computer		

F Read through the text and find the answers to these questions.

What can computer do?

Computers and microchip have become part of our everyday lives: we visit shops and offices which have been designed with the help of computers, we read magazines which have been produced on computer, we pay bills prepared by computers. Just picking up a telephone and dialing a number involves the use of a sophisticated computer system, as does making a flight reservation or bank transaction.

We encounter daily many computers that spring to life the instant they're switched on (e.g. calculators, the car's electronic ignition, the timer in the microwave, or the programmer inside the TV set), all of which use chip technology.

What makes your computer such a miraculous device? Each time you turn it on, it is a tabula rasa that, with appropriate hardware and software, is capable of doing anything you ask. It is a calculating machine that speeds up financial calculations. It is an electronic filing cabinet which manages large collection of data such as customers' lists, accounts, or inventories. It is a magical typewriter that allow you to type and print any kind of documents. It is a personal communicator that enables you to interact with other computers and with people around the world. If you like gadgets and electronic entertainment, you can even use your PC to relax with computer games.

1. Why have computers become part of our everyday lives?

.....
.....

2. What is the tabula rasa that is mentioned in the third paragraph?

.....
.....

3. What does a computer enable you to do when it is considered as a typewriter ?

.....
.....

4. How can people around the world communicate with each other?

.....
.....

G Fill in the blanks with the correct form of the verbs in brackets.

Example

House (design)with the help of computers.

Houses are designed with the help of computers.

1. Various terminal (connect)to this workstation.

2. Microcomputers (know) as 'PCs'.

3. Magazines (typeset)by computers.

4. When a particular program is run, the data (process) by the computer very rapidly.

5. The web (use) to search for information and buy product online.

6. The drug-detecting test in the Tour de France (support) by computers.

7. All the activities of the computer system (coordinate) by the central processing unit.

8. In some modern systems information (hold) in optical disks.

H Now use the below useful constructions to write these ideas.

Computers are used to

A PC can also be used for ...

Computer can help make ... control store ... keep ... provide manage ... give ... perform ... measure ... test ... provide ... access to

1/ Trong văn phòng, máy tính được dùng để viết thư , thư điện tử và lưu giữ hồ sơ khách hàng, nhà cung cấp và nhân viên.

.....
.....
.....

2/ Trong kinh doanh, máy tính được dùng để lập kế hoạch tài chính, tính tiền bạc và thực hiện các phép tính đặc biệt.

.....
.....

3/ Ở nhà, thanh niên thường dùng máy tính cá nhân để chơi trò chơi.

.....
.....

4/ Trong kinh doanh, máy tính cá nhân được dùng để xử lý văn bản và chế bản điện tử.

.....
.....

Unit 2 Personal computing

A What are they used for?



a



b



c



d

joy stick mouse stylus magnetic card reader

B Look and read. Choose the correct words and write them on the line.

1 A pen-like input device connected by a wire to the computer. It replaces the keyboard and is used to write directly on the screen to input data.

2 An input device connected by a wire to the computer when it is moved, the cursor will move along the screen in the same direction in which the device is being move.

3 A device that can read the card on which information has been magnetically recorded.

4 An input device especially helpful when playing computer games. It can be useful to the control the movemens of objects displayed on the screen.

C Listen to the interview between a market researcher and visitor to a computer exhibition. Then fill in the missing information on the line.

Interview

Name: _____

Occupation: _____

Type of PC used: _____

Reasons for choice: 1 _____

2 _____

3 _____

D Match each word with the correct definition:

- | | | | |
|---|------------------|---|--|
| 1 | mainframe | a | the set of software that controls a computer system. |
| 2 | mouse | b | a very small piece of silicon carrying a complex electrical circuit. |
| 3 | icon | c | a big computer system used for large-scale operations. |
| 4 | operating system | d | the physical portion of a computer system. |
| 5 | software | e | a device moved by hand to indicate position on the screen. |
| 6 | hardware | f | a visual symbol used in a menu instead of natural language. |
| 7 | microchip | g | data, programs, ect ., not forming part of a computer, but used when operating it. |

E Read this passage about the structure of the processor and fill in the gaps using the words below.

Structure of the processor.

The processor consists of (1) _____, which is a circuit board on which are mounted (2) _____ chips, memory chips, and other components linked together by (3) _____ lines or channels in the form of control, address, and data (4) _____. In addition, a processor has (5) _____, which are electronic circuits providing specialised functions such as graphics, or which connect a system board to (6) _____. The system board also consists of electronic devices, such as an electronic (7) _____ for controlling the speed of operation; (8) _____

....., which store numeric data during the course of processing; and various (9)
....., including sequence control register, address register, and function register.

adaptor boards	registers	microprocessor
clock	conductive	buses
system board	accumulators	input or output devices

F Circle the correct word.

- 1 *Data bus / Address bus* is used to send address details between the memory and the address register.
- 2 *Microprocessor chip / ROM* consists of an arithmetic-logic unit, one or more working registers to store data being processed, and accumulators for storing the results of calculations.
- 3 *Clock / Data bus* is a group of signal lines used to transmit data in parallel from one element of a computer to another.
- 4 *Accumulators / Registers* are groups of bistable devices used to store information in a computer system for high-speed access.
- 5 *Clock / Control bus* is an electronic circuit, usually a quartz crystal, that generates electronic pulses at fixed time intervals to control the timing of all operations in the processor.
- 6 *ROM / Microprocessor chip* is used for storing part of the operating system and application software known as 'firmware'; can only be read; cannot be written to or altered in any way.
- 7 *Accumulators / Registers* are used to store numeric data during processing.
- 8 *Control bus / Data bus* is a group of signal lines dedicated to the passing of control signals.
- 9 RAM / ROM is used for the temporary storage of application programs and data; can be written to and read from.

Unit 3 Portable computers



A Match these words with their definitions:

a	clipboard	1	surface on which pictures or data are shown
b	stylus	2	electrical force
c	screen	3	pattern used as a guide for creating letters or characters
d	grid	4	individual dot on a computer screen
e	voltage	5	network of lines crossing at right angles
f	pixel	6	pointed implement for drawing or writing
g	template	7	A reserved section of memory that is used as a temporary, behind-the-scenes staging area for data that are copied or removed from one application to another using the copy and paste and cut and paste menu functions.

B Read the text and decide whether the following statements are true (T) or false (F) in relation to the information in the text. If you think a statement is false, change it to make it true.

- 1 The American and the Japanese are working together to produce use friendlier computers.
- 2 The clipboard computer was first sold twenty years ago.
- 3 On a clipboard, an electronic pen replaces the traditional keyboard.
- 4 In the GRIDPad system, when the pen touches the screen, it informs the computer and a liquid crystal pixel appears at that point.
- 5 The software decides that one character or numbers is complete if the tip of the stylus is not in contact with the screen for more than half a second.
- 6 The whole process of recognizing letters or numbers and printing them on the screen takes every little times.

7 There are many clipboard computers sold today which are all available everywhere in the world.

8 Clipboard systems can be made to understand and kind of writing.

Delete Keys – Clipboard Technology

FOR THE LAST GENERATION, Silicon Valley and Tokyo have been working to design computers that are ever easier to use. There is one thing, however, that has prevented the machines from becoming their user-friendliest: you still have to input data with a keyboard, and that can require you to do a lot of typing and to memorize a lot of elaborate commands.

Enter the clipboard computer, a technology that has been in-development for the last 20 years but took hold in the mass market only this year. Clipboard PCs-which, as their name suggests, are not much bigger than an actual clipboard - replace the keyboard with a liquid crystal display (LCD)screen and an electronic stylus. Users input data by printing individual letters directly on the screen.

There are two technologies at work in a clipboard PC: one allows raw data to get into the computer and the other allows the computer to figure out what that data means. The first technology relies principally on hardware and varies depending on the particular computer. In one system, marketed under the name GRIDPad, the computer's LCD screen is covered by a sheet of glass with a transparent conductive coating. Voltage is sent across the glass in horizontal and vertical lines forming a fine grid; at any point on the grid, the voltage is slightly different. When the stylus - which is essentially a voltmeter - touches the screen, it informs the computer of the voltage at that point. The computer uses this information to determine where the stylus is and causes a liquid crystal pixel to appear at those coordinates. The position of the stylus is monitored several hundred times a second, so as the stylus moves across the glass, whole strings of pixels are activated.

'What we do is sort of connect the dots,' says Jeff Hawkins, the creator of GRIDPad. 'Users can then write whatever they want on the screen with a kind of electronic ink.'

Making that writing comprehensible to the computer, however, requires the help of some powerful software. When the stylus is being used, the computer is programmed to look for moments when the tip does not touch the screen for a third of a second or more. Every time this happens - and it happens a lot when somebody is printing - the software assumes that one letter or number has been written. The pixel positions of this fresh character are then passed on to the computer's pattern recognition software, which instantly identifies the letter or number written.

The software does this by first cleaning up the character - smoothing out crooked lines and removing errant dots. The remaining lines and curves are then compared with a series of templates in the computer's memory that represent hundreds of thousands of different versions

of every letter in the English alphabet and all ten numerals. When the computer finds the closest match, it encodes the character in memory and displays it on the screen as if it had been typed. The entire process takes just a fraction of a second. To delete a word you simply draw a line through it. To move to the next page, you flick the stylus at the bottom of the screen as if you are flicking the page of a book.

There are a handful of clipboard computers now on the market, including CRIDPad, which is sold in the US; Penvision, manufactured by NCR and sold around the world; and Sony's Palmtop and Canon's AI Note, both sold only in Japan. IBM and Apple are also pouring millions of dollars into the technology.

In addition to this hardware, a variety of software is also making its way to the market. Depending on the power of the computer and the sophistication of the software, clipboard systems can be programmed to understand the particular quirks of a particular user's printing; this is an especially useful feature in Japan, where elaborate kanji characters make up most of the written language. Improvements in software may soon allow machines sold in the US to understand not only printing but continuous script as well.

Given such flexibility, the designers of clipboard computers are predicting big things - and a big market - for their products. 'There's no doubt about it,' says an optimistic Hawkins. 'You're going to own one of these things in the not-too-distant future.'

C Use the information in the text to complete the dialogue *in your own words*.

A How big is a clipboard PC?

B

A Does it have a keyboard?

B

A How does the stylus work?

B

A How does the computer know when one letter or number is complete?

B

A And how does the computer recognize different letters?

B

A Can you delete a word after you have written it?

B

A Are these systems capable of recognizing joined writing?

B

D Choose the correct word to complete each sentence. You may have to change some words slightly.

1. *electron, electronic, electronics, electronically*

- a An pen is one example of an input device.
- b A computer solves problems .
- c Many students go on to work as engineers.
2. *technology, technological, technologically, technologist*
- a The computer is the greatest invention of the twentieth century.
- b There are two involved in a clipboard PC.
- c Today's computers are far superior to those used a few years ago.
3. *identify, identifying, identifiable, identity*
- a The clipboard's pattern recognition software immediately the letters and numbers written by the stylus.
- b Most computer companies will not allow people without an card to enter their premises.
- c A password is a mechanism for the computer-user and allowing access.
4. *compute, computing, computation, computerize, computerization*
- a The of the manufacturing division will be expensive in the short term, but cost-effective in the long term.
- b We should be able to our profit for next year fairly accurately with the new program.
- c I could tell from all the on the board that a maths lesson was in progress.

Unit 4 Computer essentials

A Label the elements of this computer system.

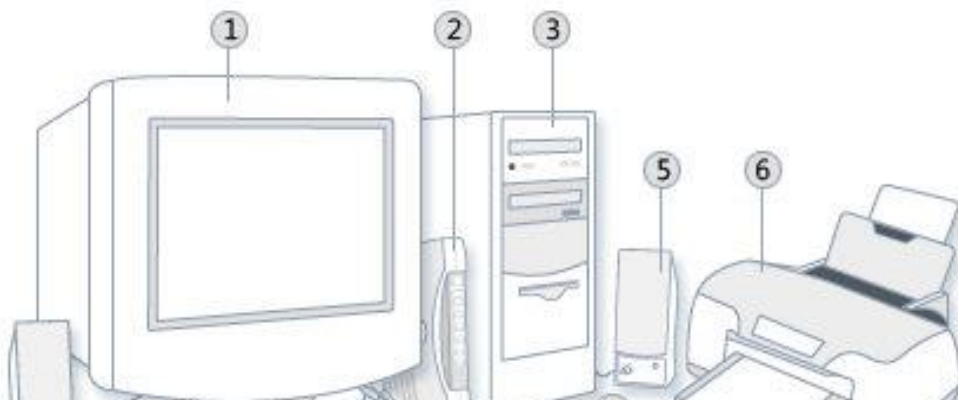

B Label the picture below with the words in the box.

laptop	desktop PC	handheld	mainframe	minicomputer
--------	------------	----------	-----------	--------------



a).....



b).....



c).....

d).....



e).....

C Read the short lecture given by John Griffiths, an expert on computer system and choose the correct answer.

Dialogue 1:

Mainframes are very large and expensive and are capable of supporting hundreds, or even thousands, of users at the same time.
They are used in large organisations for processing huge amounts of data or to control massive networks of computers.
Mainframes use more than one processor (parallel processing) which means they can process many jobs at the same time.
Early mainframes were the size of a room and got their name because they were housed in large metal 'frames'.

1. Mainframe computers are used by:
 - a. executives and businessmen.
 - b. large organizations that need to process enormous amounts of data.

2. Mainframes:
 - a. are very large and expensive
 - b. can't process many jobs at the same times

Dialogue 2:

A hand-held computer is a portable computer that is small enough to be held in one's hand. Although extremely convenient to carry, handheld computers have not replaced notebook computers because of their small keyboards and screens. Traditional hand-held computers were PDAs and devices specifically designed to provide PIM (personal information

manager) functions, such as calendar and address book. Today PocketPCs, smartphones and tablets are common consumer devices.

3. Handheld computers are
 - a. small enough to fit into the palm of one hand.
 - b. bigger than laptop.
4. Handheld computers
 - a. can be replaced notebook computers
 - b. are were PDAs (Personal Digital Assistants)

D Listen to the conversation between Linda and Jim and, then choose the best option below.

1. What did happen to Jim's computer?
 - a. Nothing happened to it
 - b. It is broken
 - c. It doesn't work
2. How many times did Jim read the manual?
 - a. two times
 - b. three times
 - c. four times
3. Why did Jim have trouble with his newcomputer?
 - a. He didn't read the manual carefully
 - b. He didn't know how to turn it on
 - c. He didn't plug it in

E Read the text and study the diagram below.

What is a computer?

Computers are electronic machine which can accept data in a certain form, process the data and give the result of the processing in a specified format as information.

These basic steps are involved in the process. First, data is fed into the computer's memory. Then, when the program is run, the computer perform a set of instructions and processes the data. Finally, we can see the results (the output) on the screen or in printed form (see the

diagram below).

Information in the form of data and program is known as **software**, and the electronic and mechanical parts that make up a computer system are called **hardware**. A standard computer system consists of three main sections: the central processing unit (CPU), the main memory and the peripherals.

Perhaps the most influential component is the **central processing unit**. Its function is to execute program instructions and coordinate the activities of all the other units. In a way, it is the ‘brain’ of the computer. The **main memory** holds the instructions and data which are currently being processed by the CPU. The **peripherals** are the physical units attached to the computer. They include storage devices and input/output devices.

Storage devices (floppy, hard or optical disks) provide a permanent storage of both data and program. **Disk drives** are used to handle one or more floppy disks. **Input devices** enable data to go into the computer’s memory. The most common input devices are the **mouse** and the **keyboard**. **Output devices** enable us to extract the finished product from the system. For example, the computer shows the output on the **monitor** or prints the results onto paper by means of a **printer**.

On the rear panel of the computer there are several ports into which we can plug a wide range of peripherals – modems, fax machines, optical drives and scanners.

These are the main physical units of a computer system, generally known as the **configuration**.

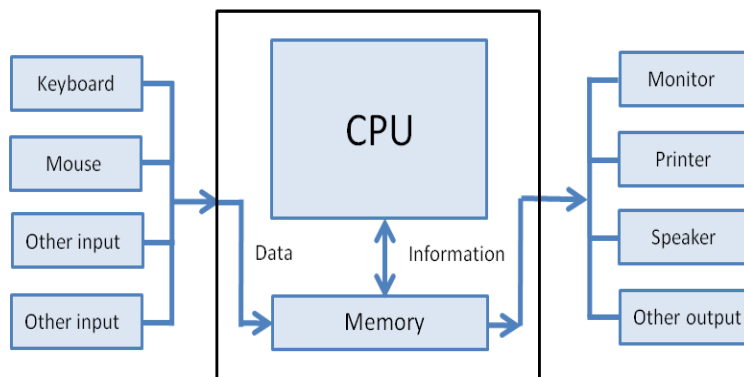

F u match the terms in the box with the appropriate explanation or definition below.

u match the terms in the

a. software	b. peripheral devices	c. monitor	d. floppy disk	e. hardware
f. input	g. port	h. output	i. central processing unit	

1. The brain of the computer.
2. Physical parts that make up a computer system.
3. Program which can be used on a particular computer system.
4. The information which is presented to the computer.
5. Results produced by a computer.
6. Hardware equipmet attached to the CPU.
7. Visual display unit.
8. Small devices used to store information. Same as 'diskette'.
9. Any socket or channel in a computer system into which an input/output device may be connected.

G Fill in the following sentences with "who" or "which".

1. That's the CPU I'd like to buy.
2. A co-processor is an extra processor chip does calculations at high speed.
3. The microprocessor coordinates the activities take place in the computer system.
4. Last night I met someone works for GM as a computer programmer.
5. A palmtop is a computer is small enough to be held in the palm of one hand.
6. A megahertz is a unit of frequency is used to measure processor speed.
7. Here's the DVD you lent me.

H Translate into English.

1. Tất cả máy tính đều có một thiết bị đầu vào, một bộ xử lý, một thiết bị đầu ra và một thiết bị lưu trữ.

.....

2. Tất cả các máy tính đều có các linh kiện phần cứng cơ bản.

.....

3. Tất cả các thông tin được xử lý phải được chuẩn bị theo cách để máy tính có thể hiểu được nó.

.....
.....

4. Do có mạch tinh vi của máy tính, dữ liệu có thể được lưu trữ hoặc xóa đi rất nhanh.

.....
.....

5. Bộ xử lý là linh kiện trung tâm của hệ thống máy tính.

.....
.....

6. Tất cả các thiết bị khác được dùng trong máy tính đều được kết nối với bộ xử lý trung tâm.

.....
.....

7. Tất cả các bộ nhớ đều được dùng để lưu thông tin.

.....
.....

Unit 5 Input/output devices

A Look at the illustrations and read the text. Name them.

Input devices are the pieces of hardware which allow us to enter information into the computer. The most common are the keyboard and the mouse. We can also interact with a computer by using one of these: a lightpen, a scanner, a trackball, a graphic tablet, a joystick or a voice recognition device.

Output devices are any devices used to send data from a computer to another device or user.



a).....

b).....

c).....



d).....

e).....

f).....



g).....

h).....

i).....



k).....

l).....

B Look and read. Choose the correct words and write them on the lines.

device input device receive output device send

1 An sends information to a computer system for processing.

Input Example



2 An reproduces or displays the results of that processing.

Output Example



3 Depending on the interaction, a can be both, referred to as an input/output or I/O device.

4 An input device can send data to another device, but it cannot data from another device.

5 An output device can receive data from another device, but it cannot data to another device.

C Read this passage about a computer mouse. Fill in the gaps with verbs from the list.

click double-click drag grab select move control

A mouse allows you to (1) the cursor and move around the screen very quickly. Making the same movements with the arrow keys on the keyboard would take much longer. As you (2) the mouse on your desk, the pointer on the screen moves in the same direction. The pointer usually looks like an I-bar, an arrow or a pointing hand, depending on what you are doing.

A mouse has one or more buttons to communicate with computer. For example, if you want to place the insertion point or choose a menu option, you just (3) (press and release) on the mouse button, the option is chosen.

The mouse is used to (4) text and items on screen. You can highlight text to be detected, or you can



the
and
the

select an item from a check-box or questionnaire.

The mouse is widely used in graphics and design. When you want to move an image, you position the pointer on the object you want to move, press the mouse button, and (5) the image to a new location on the screen. Similarly, the mouse is used to change the shape of a graphic object. For example, if you want to convert a square into a rectangle, you (6) one corner of the square and stretch it into a rectangle.

The is also used to start a program or open a document: you put the pointer on the file name and (7) on the name – that is, you rapidly press and release the mouse button twice.

D Look at the the HELP box and then rewrite the sentences below about what you should to to protect your eyes. Use modal auxiliary verbs in your sentences.

<p>HELP box Instructions and advice</p> <p>Position your keyboard at the same height as your elbows = Don't use a monitor that is fuzzy or distorts the image.</p> <p>Should/ought to</p> <p>You should position your keyboard at the same height as your elbows. = You ought to ... You shouldn't use a monitor that is fuzzy or distorts the image. = You ought not (oughtn't) to use ...</p>

1. Do not stare at the screen for long periods of time.
2. Avoid placing the monitor so that it reflects a source of bright light, such as a window.
3. Keep the screen clean to prevent distorting shadows.
4. If you work in an office with a large number of computers, don't sit too close to the sides or backs of the monitors.
5. Buy a protective filter that cuts down the ELF (extremely low frequency) emissions.

E Translate into English.

- 1 Một hệ thống máy tính cần có phần cứng và phần mềm để hoàn thiện.

.....

2 Một hệ thống gồm các thành phần kết nối chặt chẽ với nhau.

.....

3 Máy tính là một phần cứng.

.....

4 Bộ xử lý thường đề nói tới bộ CPU.

.....

5 Từ máy tính để chỉ bộ xử lý bộ nhớ và bộ nhớ trong.

.....

6 Phần mềm các hệ thống thường để chỉ các chương trình.

.....

7 Máy tính sử dụng các mục thông tin đã được chuẩn bị trước.

.....

Unit 6 Inside the system

A. Read the advertisement and translate the technical specification into your own language.



- Pentium 4 microprocessor at 2 GHz (2,000 MHz)
- 256 megabytes of RAM, upgradable to 1.5 GB
- 80 GB hard disk
- Comes with Microsoft Windows

B Rea the text. Choose a word from the box. Write the correct word next to the number 1 – 5.

power	chip	microprocessor	The CPU	RAM
-------	------	----------------	---------	-----

The three functions of a (1) are controlling the operations of a computer's central processing unit, transferring data from one location to another and doing mathematical calculations using logarithms. A microprocessor is thought to function like a human brain and is essential in the operation of computers and digital devices.

The Central Processing Unit (CPU) which is the microprocessor chip that's mounted on the system board. (3) is essentially the heart and brain of a computer. All the programs you run or data that you enter into a computer is actually manipulated directly or indirectly by the CPU. Ultimately, the CPU determines the capabilities and speed of the computer. The CPU is the most powerful (3) in the computer and can operate at rates of 3200 million cycles per second (3.2 GHz) and greater. The CPU works at a speed limited by its design and is controlled by an electronic clock crystal and timing chip. They are measured in cycles per second, or hertz. The CPU operates so quickly (millions of times per second) that the terms are megahertz, or MHz, and gigahertz, GHz to describe their speeds

The main difference between RAM and ROM is that ROM is a read-only form of memory that cannot be modified. ROM is classified as a nonvolatile memory, whereas (4) is a volatile memory. RAM memory can also be found in other electronic devices apart from computers, including tablets, smartphones and printers. As RAM is a volatile form of memory, it requires electric power to keep the data. ROM holds on to the data with or without (5)

B Read the text below. Decide if the sentences are true (T) or false (F), and rewrite the false ones to make them true.

What's inside a PC system?

The nerve centre of a PC is the central processing unit or CPU. This unit is built into a single microprocessor chip – an integrated circuit – which executes program instructions and supervises the computer's overall operation. The unit consists of three main parts.

the **control unit**, which examines the instructions in the user's program, interprets each instruction and causes the circuits and the rest of the components – disk drives, monitor, ect. – to be activated to execute the functions specified;

the **arithmetic logic unit** (ALU), which performs mathematical calculations (+, - , ect.) and logical operations (and, or, ect.);

the **registers**, which are high-speed units of memory used to store and control information. One of these registers is the program counter (PC) which keep track of the next instruction to be performed in the main memory. Another is the instruction register (IR) which holds the instruction that is currently being executed (see fig. 1).

One area where microprocessors differ is in the amount of data – the number of bits – they can work with at a time. There are 16, 32 and 64-bit processors. The computer’s internal architecture is revolving so quickly that the new 64-bit processor are able to address 4 billion times more information than a 32-bit system.

The program and data which pass through the central processor must be loaded into the **main memory** (also called the **internal memory**) in order to be processed. Thus, when the user runs an application, the microprocessor looks for it on secondary storage devices (disks) and tranfers a copy of the application into the RAM area. RAM (random access memory) is temporary, i.e. its information is lost when the computer is turned off. However, The ROM section (read only memory) is permanent and contains instructions needed by the processor.

Most of today’s computers have internal **expansion slots** that allow users to install adapters of expansion boards. Popular adapters include high-resolution graphics boards, memory expansion boards, and internal modems.

The power and performance of a computer is partly determined by the speed of its microprocessor. A clock provides pulses at fixed intervals to measure and synchronize circuits and units. The clock speed is measured in MHz (megahertz) or GHz (gigahertz) and refers to the frequency at which pulses are emitted. For example, a CPU running at 1,600 MHz (1,600 million cycles per second) will enable the computer to handle the most demanding applications.

Central processing unit (CPU)

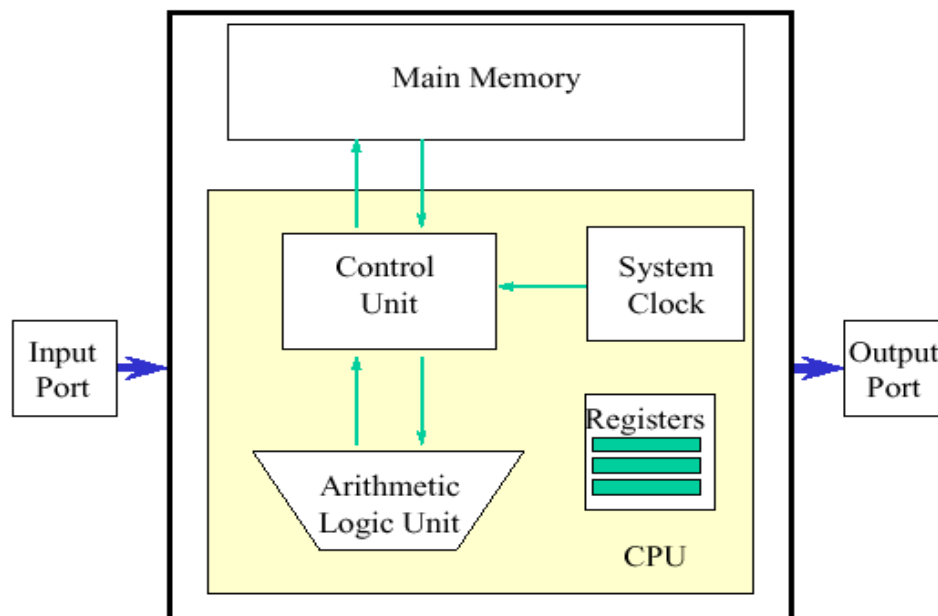

Figure 1



A RAM chip



Microprocessor chip

Popular chips

- Intel's Pentium (as shown)
- AMD's athlon
- Apple and IBM's Power PC
- Sun's UltraSPARC

The RAM capacity can sometimes be expanded by adding extra chips. These are usually contained in small circuit boards called in-line memory modules (SIMs). Modern Pentium processors also accept dual in-line Memory module (DIMMs), which allow for a wider data path.

1. The CPU directs and coordinates the activities taking place within the computer system.
2. The arithmetic logic unit performs calculations on the data.
3. 32-bit processors can handle more information than 64-bit processor.
4. A chip is an electronic device composed of silicon elements containing a set of integrated circuits.
5. RAM, ROM and secondary storage are the components of the main memory.
6. Information cannot be processed by the microprocessor if it is not loaded into the main memory.
7. 'Permanent' storage of information is provided by RAM (random access memory).
8. The speed of the microprocessor is measured in gigahertz or megahertz. One GHz is equivalent to one thousand MHz. One MHz is equivalent to one million cycles per second.

C Match the questions in column A to the answer in column B.

- | | | | |
|----|---|---|--|
| 1 | What are the main parts of the CPU? | a | A bit (short for binary digit) is the smallest unit of data in a computer |
| 2 | What is RAM? | b | The three major components of a CPU are the arithmetic logic unit, the control unit and the cache. |
| 3 | What memory section is permanent and contains Instructions needed by the CPU? | c | ROM section is permanent and contains instructions needed by the CPU. |
| 4 | What information is lost when the computer is switched off? | d | Random access memory, or RAM, is memory storage on a computer that holds data while the computer is running so that it can be accessed quickly by the processor. |
| 5 | What is the typical unit used to measure RAM memory and storage memory? | e | Megahertz (MHz) is measurement unit that measure wave frequencies, as well as the speed of microprocessors. |
| 6 | What is the meaning of the acronym SIMM? | f | GB (Gigabyte) is the typical unit used to measure RAM memory and storage memory. |
| 7 | What is megahertz? | g | Everything we are typing in is lost when the computer is switched off. |
| 8 | What is the ALU?
What does it do? | h | A SIMM (single in-line memory) is a module containing one or several random access memory (RAM) chips on a small circuit board with pins that connect to the computer motherboard. |
| 9 | What is the abbreviation for 'binary digit'? | i | An arithmetic-logic unit (ALU) is the part of a computer processor (CPU) that carries out arithmetic and logic operations on the operands in computer instruction words. |
| 10 | How can we store data and programs permanently? | j | All permanent data on a computer is stored on the Hard Drive Disk (HDD). This piece of hardware is capable of storing several hundred gigabytes of information. |

D Make sentence as in the example.

Example:

Not easy/write instructions in Pascal

It is not easy to write instructions in Pascal.

1. advisable/test the program under different conditions

.....

2. expensive/set up a data-processing area

.....

3. unusual for a program/work correctly the first time it is tested

.....

4. difficult for students/learn FORTAN

.....

5. important/consider the capabilities of the programming language

.....

6. quite easy/write instructions in BASIC

.....

E Translate into English.

1. Bộ xử lý trung tâm chỉ bao gồm bộ phận logic số học và bộ điều khiển.

.....

.....

2. Bộ xử lý trung tâm quản lý tất cả các thao tác diễn ra trong một máy tính.

.....

.....

3. Bộ xử lý không thể khai thác thông tin nếu thông tin không có trong bộ nhớ chính.

.....
.....
4. Chỉ sau khi số liệu đã được xử lý thì nó mới có thể được chuyển ra thiết bị ngoại vi.
.....
.....

Unit 7 Operating system

A Read the text. Choose a word from the box. Write the correct word next to numbers 1 – 5.

An operating system is a master control (1) which controls the functions of the computer system and the (2) program.

The operating system is stored on (3) and has to be loaded into the internal memory (RAM) by the start-up process ('booting').

Balancing system resources between different applications, controlling printing, controlling access and file

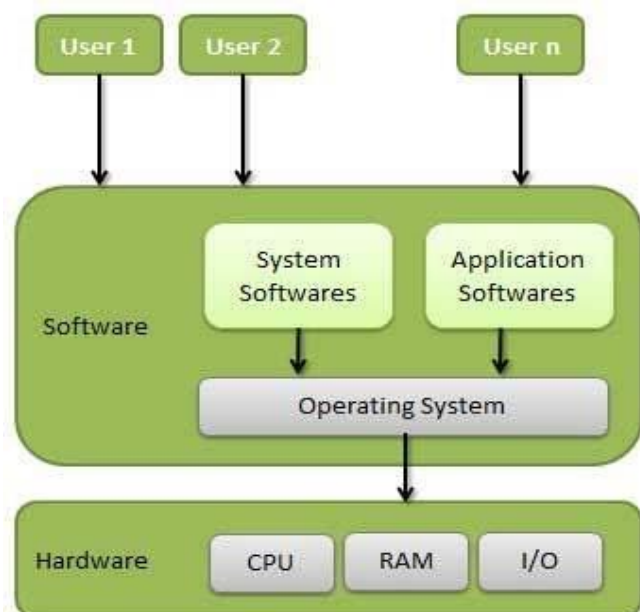

locking, controlling terminals in a multi-user (4), handling the use of memory by the programs running, monitoring hardware (5)

disk system failures application environment

B Match these common DOS commands with the appropriate explanation.

- | | | | |
|----|-------------|---|--|
| 1 | BACKUP | a | searcher for a special string of text in a file. |
| 2 | CHDIR or CD | b | allows a text file from the current directory to be displayed on screen. |
| 3 | CHKDSK | c | allows the user to change the name of a file. |
| 4 | CLS | d | saves the contents of the hard disk to a floppy disk for security purposes. |
| 5 | DEL | e | is used to when it is necessary to change the current directory. |
| 6 | DIR: SORT | f | clears data from the screen. |
| 7 | REN | g | alphabetically sorts and lists a disk directory |
| 8 | TYPE | h | makes back-up copies of the contents of one disk to another. |
| 9 | FIND | i | deletes a specified file from the current directory, specified drive, or speified path. |
| 10 | DISKCOPY | j | produces a status report of the current logged-on disk, indicating the amount of disk space used, the available capacity (in bytes), and the numbers of files on disk. |

C Read the text. Write some words to complete the sentences.

General features of operating systems

An operating system is a *master control program* which controls the functions of the computer system as a whole and *the running of application programs*. All computers do not use the same operating systems. It is therefore important *to assess the operating system* used on a particular model before initial commitment because some software *is only designed* to run under the control of specific operating systems. Some operating systems are adopted as «industry standards» and these are the ones which should be evaluated because they normally have a *good software base*. The reason for this is that *software houses* are willing to *expand resources* on the development of application packages for machines functioning under the control of an operating system which is widely used. The cost of software is likely to be lower in such circumstances as the development costs are spread over a greater number of users, both actual and potential.

- 1 The functions of the computer system and the running of application programs are controlled by
- 2 It is important to access the operating system on a computer before buying it because some software is only under the control of specific operating system.

Mainframe computers usually *process several application programs concurrently*, switching from one to the other, for the purpose of *increasing processing productivity*. This is known as *multiprogramming* (multi-tasking in the context of microcomputers), which *requires a powerful operating system incorporating work scheduling facilities* to control the *switching between programs*. This entails reading in data for one program while the processor is performing computations on another and printing out results on yet another.

- 3 is the process of several application programs currently, switching from one to the other, for the purpose of increasing processing productivity.

In multi-user *environments* an operating system is required to control terminal operations *on a shared access basis* only one user can access the system at any moment of time. The operating system allocates control to each terminal *in turn*. Such also require a system for *record locking and unlocking*, to prevent one user attempting to read a record whilst another user *is updating* it, for instance. The first user *is allocated control* to write to a record (or file in some instances), other users being denied access until the record is updated and unlocked.

- 4 On a shared access basis only can access the system at any moment of time.
- 5 In multi-user environments, systems require a system for record locking and to prevent one user attempting to read a record whilst another user is updating it, for instance.

Some environments operate in *concurrent batch and real-time mode*. This means that a «background» job deals with routine *batch processing* whilst the «foreground» job deals with *real-time operations* such as airline seat reservations, on-line booking of hotel accommodation, or *control of warehouse stocks*, etc. *The real-time operation has priority*, and the operating system *interrupts* batch processing operations *to deal with real-time inquiries or file updates*. The stage of *batch processing* attained at the time of *the interrupt* is temporarily *transferred to backing storage*. *The real-time operation* having been dealt with, *the interrupted program* is transferred back to internal memory from *backing storage*, and *processing recommences from a «restart» point*. The operating system also copies to disk *backing storage* the state of *the real-time system* every few minutes (periodic check points) to provide *a means of «recovering» the system in the event of a malfunction*.

- 6 has priority and the operating system interrupts batch processing operations to deal with real-time enquiries or file updates.

- 7 Every few minutes, the operating system also copies to disk backing storage the state of the real-time system a means of ‘recovering’ the system in the event of a malfunction.

An operating system *is stored* on disk and has *to be booted* into the *internal memory* (RAM) where it must *reside throughout processing* so that commands are instantly available. The operating system commands *may exceed the internal memory capacity* of the computer in which case only that portion of the OS which is frequently used is retained internally, other modules being read in from disk as required. Many microcomputers function under the control of disk operating system known as DOS.

- 8 An operating system has to booted into when it is stored on disk.

- 9 control many microcomputers function.

D Here is a list of typical tasks performed by an operating system. In each case the main verb has been omitted. Fill in the blanks from the words given. Sometimes more than one may apply.

A typical operating system will:

1. _____ input and output devices.
2. _____ the status of hardware devices.
3. _____ hardware interrupts.
4. _____ new disks.
5. _____ disk directories.
6. _____ disk reading and writing operations.
7. _____ disk errors.
8. _____ disk commands relating to the deletion, copying, renaming, and dumping of files.
9. _____ execute, monitor, format, diagnose

E Read the sentences. Write one word on each line.

grid – data – palmtop – template – clipboard – pixel – stylus – interrupt - delete
--

- 1 A computer that is small enough to hold in the hand.
- 2 An lectronic pen.
- 3 To eraser or omit.

- 4 One type of portable computer which operates with an electronic pen.
- 5 The information that the computer processes.
- 6 A network of lines crossing at right angles.
- 7 A signal to a processor to suspend temporarily the current sequence of instructions.
- 8 A pattern used as a guide for creating letters or characters.
- 9 An individual dot on a computer screen.

Unit 8 Computer networks



A Find the answers of these questions.

- 1 What is a LAN?
 - 2 What is a WAN?
 - 3 What is a distributed system?
- a is one in which the processing is spread over a number of computers connected by a network. The network is used to pass information and control the processes.

- b A local area network: this provides the ability for a group of computers to communicate directly within a relatively restricted area, usually within one building. It does not require the use of public telephone lines.
- c A wide area network: this provides the ability for computers to communicate over large distances using public telephone lines. These may be international. It may be used to connect up a number of LANs.

B Match these words and phrases with their definitions.

- | | | | |
|---|----------------|---|--|
| 1 | protocol | a | analyse the syntax of a string of input symbols |
| 2 | bulletin board | b | a teleconferencing system allowing users to read messages left by other users |
| 3 | user interface | c | agreement governing the procedures used to exchange information between co-operating computers |
| 4 | make a query | d | means of communication between a human user and a computer system |
| 5 | parse | e | taking place at exactly the same time as something else |
| 6 | synchronous | f | request a search |

C Read quickly through the text below, then match each paragraph with the appropriate summary.

- a Network uses, past and present
- b How distributed system network
- c Network and the future
- d What networks are and how they operate
- e The growth of networks, past and present

Computer networks

1) Computer networks link computers by communication lines and software protocols, allowing data to be exchanged rapidly and reliably. Traditionally, networks have been split between wide area networks (WANs) and local area networks (LANs). A WAN is a

network connected over long- distance telephone lines, and a LAN is a localized network usually in one building or a group of buildings close together. The distinction, however, is becoming blurred. It is now possible to connect up LANs remotely over telephone links so that they look as though they are a single LAN.

2) Originally, networks were used to provide terminal access to another computer and to transfer files between computers. Today, networks carry e-mail, provide access to public databases and bulletin boards, and are beginning to be used for distributed systems. Networks also allow users in one locality to share expensive resources, such as printers and disk-systems.

3) Distributed computer systems are built using networked computers that co-operate to perform tasks. In this environment each part of the networked system does what it is best at. The high-quality bit- mapped graphics screen of a personal computer or workstation provides a good user interface. The mainframe, on the other hand, can handle large numbers of queries and return the results to the users. 4) In a distributed environment, a user might use his PC to make a query against a central database. The PC passes the query, written in a special language (e.g. Structured Query Language -SQL), to the mainframe, which then parses the query, returning to the user only the data requested. The user might then use his PC to draw graphs based on the data. By passing back to the user's PC only the specific information requested, network traffic is reduced. If the whole file were transmitted, the PC would then have to perform the query itself, reducing the efficiency of both network and PC.

5) In the 1980s, at least 100,000 LANs were set up in laboratories and offices around the world. During the early part of this decade, synchronous orbit satellites lowered the price of long-distance telephone calls, enabling computer data and television signals to be distributed more cheaply around the world. Since then, fibre-optic cable has been installed on a large scale, enabling vast amounts of data to be transmitted at a very high speed using light signals.

6) The impact of fibre optics will be considerably to reduce the price of network access. Global communication and computer networks will become more and more a part of professional and personal lives as the price of microcomputers and network access drops. At the same time, distributed computer networks should improve our work environments and technical abilities.

D Read the summary of the text and fill in the gaps using the list of words below.

Computer networks link computers locally or by external communication lines and software ¹ , allowing data to be exchanged rapidly and reliably. The ² between local area and wide area networks is, however, becoming unclear. Networks are being used to perform increasingly diverse tasks, such as

carrying e-mail, providing access to public databases, and for ³ []. Networks also allow users in one locality to share resources.

Distributed systems use networked computers. PCs or ⁴ [] provide the user ⁵ []. Mainframes process ⁶ [] and return the results to the users. A user at his PC might make a query against a central database. The PC passes the query, written in a special language, to the mainframe, which then ⁷ [] the query, returning to the user only the data requested. This allows both the network and the individual PC to operate efficiently.

In the 1980s, at least 100,000 ⁸ [] were set up world-wide. As ⁹ [] orbit satellites have lowered the price of long-distance telephone calls, data can be transmitted more cheaply. In addition, ¹⁰ [] cable has been installed on a large scale, enabling vast amounts of data to be transmitted at a very high speed using light signals. This will considerably reduce the price of network access, making global networks more and more a part of our professional and personal lives. Networks should also improve our work ¹¹ [] and technical abilities.

<i>distinction</i>	<i>fibre-optic</i>	<i>protocols</i>	<i>synchronous</i>
<i>distributed systems</i>	<i>LANs</i>	<i>queries</i>	<i>workstations</i>
<i>environments</i>	<i>parses</i>	<i>screen handling</i>	

E Fill in each gap with an appropriate word.

power – avoid – out – experience – well – qualified – familiar – without – offices – anyone - operation

When you're installing a LAN, you may be (1) your computers for as much as a day or so. A lot depends on how (2) the installation proceeds, and that depends on your own (3) Professional installers can have each of your machines (4) of (5) for only a few minutes at a time. If you can't live without your computers for a while, you might want to (6) doing it yourself.

Installing a LAN involves running cable to several (7) This may require you to install junction boxes in walls, do the wiring, and may be install electrical (8) as well. If you aren't (9) with these skills, and if you aren't a (10) electrician, you will need to hire someone for this part, at least. Of course, if you are installing your LAN in one room, then you might not need to hire (11)

Unit 9 Computer viruses



A Answer these questions.

A computer virus is an unwanted program that has entered your system without you knowing about it. Viruses are often hidden on computer disks inside a file containing a legitimate program so that they are not easy to detect without special tools. They are often spread by the sharing of games or other disks, although viruses have also been found on disks sold by reputable software manufacturers. It may damage, alter, or interfere with the normal running of your computer, or it can be harmless but irritating, affecting only the screen.

- 1 What is a computer virus?
- 2 Why are viruses not easy to detect?
- 3 How are viruses spread?
- 4 How does a virus work?

B Match the words and definitions listed below.

- | | | | |
|---|-------------|---|--|
| 1 | a detonator | a | a protective device |
| 2 | an infector | b | to remove all traces of something |
| 3 | to boot | c | a device used to set off an explosion or other destructive process |
| 4 | to trigger | d | to discover or recognize that something is present |
| 5 | to eraser | e | to set a process in motion |
| 6 | pirated | f | something which transmits a disease or virus |
| 7 | a shield | g | stolen, obtained without the owner's consent |
| 8 | to detect | h | to load the operating system into memory |

C Read the text and decide whether the following statements are true (T) or false (F). If you feel a statement is false, change it to make it true.

A computer virus –an unwanted program that has entered your system without you knowing about it -has two parts, which I'll call the infector and the detonator. They have two very different jobs. One of the features of a computer virus that separates it from other kinds of computer program is that it replicates itself, so that it can spread (via floppies transported from computer to computer, or networks) to other computers.

After the infector has copied the virus elsewhere, the detonator performs the virus's main work. Generally, that work is either damaging data on your disks, altering what you see on your computer display, or doing something else that interferes with the normal use of your computer.

Here's an example of a simple virus, the Lehigh virus. The infector portion of Lehigh replicates by attaching a copy of itself to COMMAND.COM (an important part of DOS), enlarging it by about 1000 bytes.

So let's say you put a floppy containing COMMAND.COM into an infected PC at your office- that is, a PC that is running the Lehigh program. The infector portion of Lehigh looks over DOS's shoulder, monitoring all floppy accesses. The first time you tell the infected PC to access your floppy drive, the Lehigh infector notices the copy of COMMAND.COM on the floppy and adds a copy of itself to that file.

Then you take the floppy home to your PC and boot from the floppy. (In this case, you've got to boot from the floppy in order for the virus to take effect, since you may have many copies of COMMAND.COM on your hard and floppy disks, but DOS only uses the COMMAND.COM on the boot drive.)

Now the virus has silently and instantly been installed in your PC's memory. Every time you access a hard disk subdirectory or a floppy disk containing COMMAND.COM, the virus sees that file and infects it, in the hope that this particular COMMAND.COM will be used on a boot disk on some computer someday.

Meanwhile, Lehigh keeps a count of infections. Once it has infected four copies of COMMAND.COM, the detonator is triggered. The detonator in Lehigh is a simple one. It erases a vital part of your hard disk, making the files on that part of the disk no longer accessible. You grumble and set about rebuilding your work, unaware that Lehigh is waiting to infect other unsuspecting computers if you boot from one of those four infected floppies.

Don't worry too much about viruses. You may never see one. There are just a few ways to become infected that you should be aware of. The sources seem to be service people, pirated games, putting floppies in publicly available PCs without write-protect tabs, commercial software (rarely), and software distributed over computer bulletin board systems (also quite rarely, despite media misinformation).

Many viruses have spread through pirated –illegally copied or broken -games. This is easy to avoid. Pay for your games, fair and square.

If you use a shared PC or a PC that has public access, such as one in a college PC lab or a library, be very careful about putting floppies into that PC's drives without a write-protect tab. Carry a virus-checking program and scan the PC before letting it write data onto floppies.

Despite the low incidence of actual viruses, it can't hurt to run a virus checking program now and then. There are actually two kinds of antivirus programs: virus shields, which detect viruses as they are infecting your PC, and virus scanners, which detect viruses once they've infected you.

Viruses are something to worry about but not a lot. A little common sense and the occasional virus scan will keep you virus-free.

Remember these four points: Viruses can't infect a data or text file. Before running an antivirus program, be sure to cold-boot from a write-protected floppy. Don't boot from floppies except reliable DOS disks or your original production disks. Stay away from pirated software.

- 1 Viruses cannot be spread through a computer network, only via floppies transported from computer to computer.
- 2 The viruses will spread as soon as you put the infected floppy in your PC.
- 3 The infected works by interfering in some way with the normal use of your computer.

- 4 The detonator in Lehigh works by altering what you see on your screen.
- 5 Most viruses spread through pirated games.
- 6 You should run an antirirus program every time you use your computer.
- 7 There are not very many viruses in circulation.
- 8 Virus shields are more effective than virus scanners.

D These are questions about the text. Write the questions.

- 1 Two, one that infects and one that does the damage.
- 2 By interfering in some way with the normal use of the computer.
- 3 After it has infected four copies of COMMAN.COM
- 4 Every time you access a hard disk subdirectory or a floppy disk containing COMMAND.COM.
- 5 Yes, by using your common sense and by occasionally scanning for them.

E Decide if the words and phrases below have a ‘protective’ or ‘destructive’ meaning as they are used in the unit, then put them under the correct headling.

- detonator infector eraser pirated
- infect write-protect tab worm virus scanner
- hacker password smart card shield
- signature cipher keyboard lock access control

Productive	Destructive

Unit 10 Word Processing

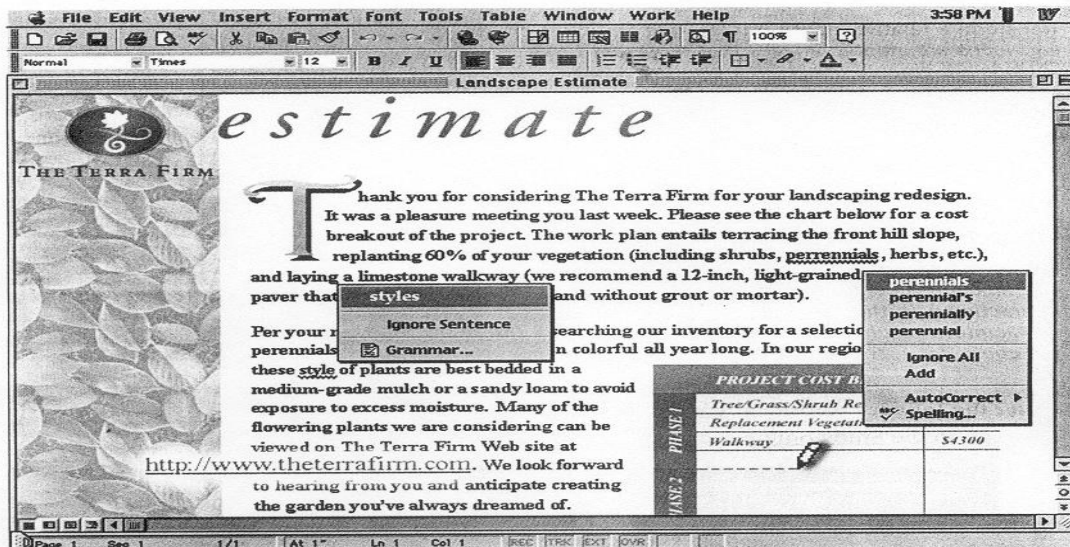

A screen from Microsoft Word for the Macintosh. Word for Windows works the same way. WordPerfect, Lotus Word Pro and Nisus Writer also have multiple typefaces, windows, pull-down menus and other graphical tools

A Read the questions and choose the best answer.

- 1 What is a word processor?
- 2 What makes word processor superior to traditional typewriters?
- 3 Make a list of the most important features offered by word processors.

A Microsoft Word, Word Perfect, OpenOffice.org Writer, word. Word is probably the most popular, as it often comes ready-installed with windows.

B A word processor can be use to compose, edit, format and print any sort of Printable material. It is mainly used to write memos, briefs, technical reports and Business letters. It also allows you to merge text from one file into another file. This is very useful for producing format but with different data.

C A word processor is a computer program which mainpulates text and produces documents suitable for printing.

B Moving text is a process of cutting and pasting. Here is the steps of this process. Put them in the right orders.

Now you have to options: to replace all instances of the text, click Replace All; to move through the document and Replace only specified instances, click Find Next. This is a safer option. Do not click Replace All unless you are certain that every instance of the text should be replaced.

Next, go to the Edit menu and select Replace. This displays a dialog box.

To locate the first instance of the specified text, click Replace.

First, click where you want to start searching for the text.

As you can see in the illustration, you type the text you want to find (computer programmer) in the Find what box, and the new text (software develop) in the Replace box.

C Two friends are talking about how to move text by using the ‘Cut and Paste’ technique. Read the conversation and complete it with words from the box.

Finally	command	First	Edit
now	mistake	Next	insertion

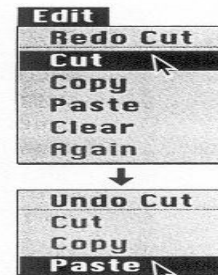

A: Do you know how I can move this paragraph? I want to put it at the end of this page.

B: Er ... I think so. (1) you use the mouse to select the text that you want to move and then you choose the Cut (2) from the Edit menu.

A: Like this?

B: Yes. The selected text disappears and goes onto the Clipboard. And (3) you find where you want the text appear and you click to position the (4) point in this place.

A: Mm ... is that OK?

B: Yes, it's that's where you want it. (5) choose Paste from the (6) menu, or hold down Command and press V. (7) check that the text has appeared in the right place.

A: What do I do if I make a (8)

B: You can choose Undo from the Edit menu which will reverse your last editing command.

A: Brilliant! Thanks a lot.

B: That's OK.

D Three major features that word processors offer are spell checkers, online thesauruses and grammar checkers. Read the descriptions of these features and match them with the dialog boxes.

online thesaurus Grammar checkers Spell checkers

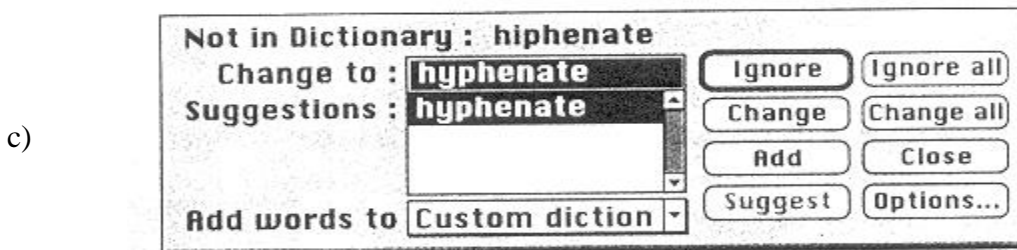
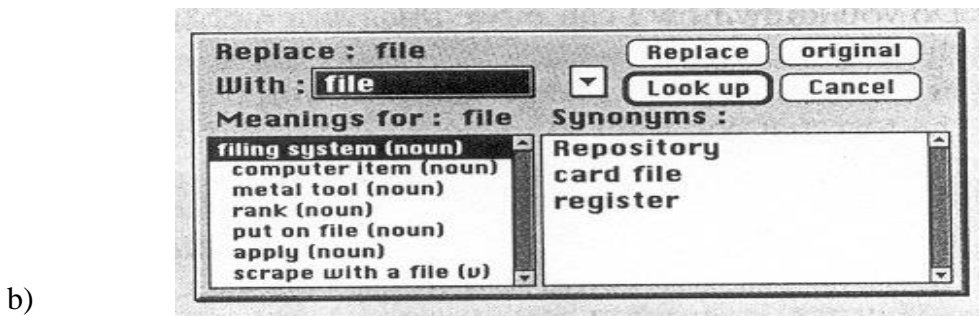
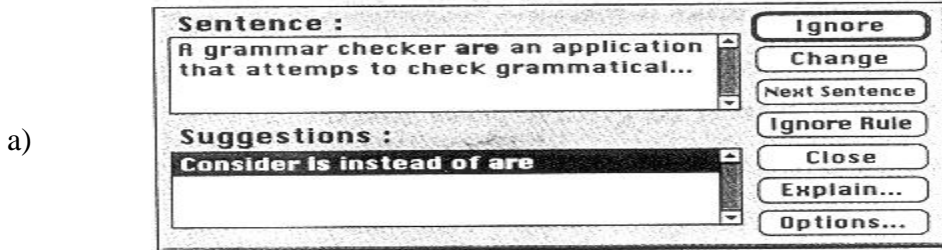

1 can be used to compare words in the program's dictionary to those used in the user's document. The spell checker points out any words it cannot match, notifies the user and allows to make any changes; it sometimes even suggests possible correct spellings. However, this does not mean that all the words in the document are spelled correctly.

A word may be spelled correctly but still be wrong (two instead of two, for instance). This is a good first step at proofing a document because it can find many common errors, but users will still need to proofread documents to ensure complete accuracy.

2 Many word processors include an with which user can look up different words to use in similar instances. Like a conventional thesaurus, this database of words contains definitions and suggestions of words with similar and opposite meanings. Some even include information about pronunciation and histories of evolving meaning.

3 are applications that just spelling. They count words in sentences to flag possible run-on sentences. They look for words that show possible conflicts between verbs and subjects and they offer advice about corrections. Grammar checkers are a step beyond spell checkers, but they are still not a substitute for a human editor. Their power comes not from knowing every grammatical rule, but from questioning the writer about certain parts of the text.

This gives the writer another chance to think about what he or she has written.; The computer can alert writer to problems that wouldn't be obvious to them otherwise.

E Match the words and expressions on the left with their explanations on the right.

- | | | | |
|---|----------------------|---|--|
| 1 | retrieve | a | text printed in the top margin |
| 2 | typefaces | b | recover information from a computer system |
| 3 | header | c | letter, number or symbol that appear below the baseline of the row of type; commonly used in maths formulas. |
| 4 | footer | d | text printed in the bottom margin |
| 5 | unscripted character | e | division of words into syllables by a short dash or hyphen |
| 6 | hyphenation | f | styles for set of characters; sometimes called 'fonts' |

F Translate into English.

- 1 Làm sao để tôi chèn ảnh của mình vào trong tài liệu văn bản này?
- 2 Bạn có thể ghi âm giọng nói để chèn những lời bình luận vào trong tài liệu.
- 3 Viết thư, lời nhắn hay báo cáo là những cách mà hầu hết người ta đều dùng máy tính.
- 4 Những đặc tính như Search và Replace cho phép người dùng tìm kiếm một cụm từ đặc biệt hoặc từ cho dù nó ở chỗ nào trong phần văn bản.

Unit 11 Faces of the Internet



A Read the two texts below and make a question for each of the texts.

.....

1 The Internet is a global network of computer networks, which allows organizations and individuals to share all sorts of information and computer resources.

.....

2 You can send and receive email, explore the Web, transfer files, have live conversations, take part in online forums, use remote computers. You can use the Web to find and download games, music or videos, buy products online, search for informations, etc.

B Which Internet utility (1 to 7) would you use to do each of these tasks (a to g)?

- | | | | |
|---|--------------------|---|---|
| 1 | e-mail | a | send a message to another person via the Internet |
| 2 | Web browser | b | transfer files from the Internet to your hard disk |
| 3 | Newsreader | c | have a live conversation (usually typed) on the Internet |
| 4 | IRC/chat program | d | connect to a remote computer by entering certain Instructions and run program on it |
| 5 | FPT software | e | take part in public discussion areas, called Newsgroups |
| 6 | Video conferencing | f | fetch and view Web pages on the Internet |
| 7 | Telnet | g | participate in live conversations, using text, audio and video |

C Reading

Internet software

Getting connected

The language used for data transfer on the Internet is known as TCCP (transmission control protocol/Internet protocol). This is like the Internet operating system.

The first program you need is a PPP (point to point protocol) driver. This piece of software allows the TCP/IP system to work with your modem; it dials up your Internet service provider (ISP), transmits your password and log-in name and allows Internet programs to operate.

E-mail

E-mail is your personal connection to the Internet. It allows you to exchange messages with people all over the world. It can include text, pictures, and even audio and animation.

When you set up an account with an ISP, you are given a unique address and anyone can send you e-mail. The mail you receive is stored on the server of your ISP until you next connect and download it to your hard disk.

Web browsers

The Web is a hypertext-based system where you can find news, pictures, games, online shopping, virtual museums, electronic magazines — any topic you can imagine.

You navigate through the Web using a program called a 'browser', which allows you to search and print Web pages. You can also click on keywords or buttons that take you to other destinations on the net. This is possible because browsers understand hypertext markup language (HTME), a set of commands that indicate how a Web page is formatted and displayed.

Irc, audio and video chatting

IRC — Internet relay chat — is a system for real-time (usually typed) conversation. It's easy to use. To start a chat session you run an IRC program, which connects you to an IRC server — a computer dedicated to IRC. Then you join a channel, which connects you to a single chat area. Next you type a message and the other participants can see it.

Internet telephone and video chatting are based on IRC protocols. Videoconferencing 4 programs enable users to talk to and see each other, and collaborate. They are used in intranets — company networks that use Internet software but make their Web site accessible only to employees and authorized users.

FTP and Telnet

With **FTP** software you can copy programs, games, images and sounds from the hard disk of a remote computer to your hard disk. Today this utility is built into Web browsers.

A **Telnet** program is used to log directly into remote computer systems. This enables you to run programs kept on them and edit files directly.

Newsgroups

Newsgroups are the public discussion areas which make up a system called 'Usenet'. The contents of the newsgroups are contributed by people who send articles (messages) or respond to articles. They are classified into categories: *comp* (computers), *misc* (miscellaneous), *news* (news), *rec* (recreation), *soc* (society), *sci* (science), *talk* and *alt* (alternative).

Task Choose the right answer.

- 1 An Internet service provider (ISP) is
 - a) a program that connects you to the Internet.
 - b) a company that gives you access to the Internet.
- 2 HTML is
 - a) the software which allows you to fetch and see Web pages.
 - b) the codes used to create hypertext documents for the Web.
- 3 An IRC channel is
 - a) an IRC discussion area.
 - b) a computer system dedicated to IRC.
- 4 Usenet is
 - a) big system of public discussion groups.
 - b) a newsgroup.
- 5 An intranet is
 - a) like a small version of the Internet inside a company.

b) a commercial online service.

D Use the given words to make them complete sentences.

1 with friends / chat / visit / you / do / What web site?

2 in / you / are / Which chat channels / interested?

3 during / web chats / talk / you / strangers / Do / with?

4 real name / nickname / or / you / Do / use / your?

E Translate into English.

1 Bạn có thường truy cập Internet không?

2 Bạn dùng chương trình thư điện tử nào?

3 Bạn gửi thư điện tử cho ai?

4 Bạn có sử dụng điện thoại di động để truy cập Internet không?

5 Bạn có chơi các trò chơi trực tuyến không?

Unit 12 New technologies

A Read the texts. Write words to complete the sentences. Use 1, 2, 3 or 4 words.

1 Not long ago, mobile phones could just transmit voice and SMS message. Now they can display Internet information thanks to the Wireless Application Protocol or WAP.



Some hybrid models combine a phone with a PDA. They look like a regular phone with a keypad and a small screen on its front. But you flip up the front cover you find a large screen that is touch-sensitive. Some include a virtual keyboard which pops up when you want to enter email text or a WAP address.

But the future is called 'third-generation' (3G) mobiles. They transmit a caller's picture and voice simultaneously. 3G mobile phones deliver user information, e-commerce, games and videoconferencing via fixed, wireless and satellite networks.

- 2 Internet TV sets allow you to surf the Web and have e-mail while you are watching TV, or vice versa. Imagine watching a film on TV and simultaneously accessing a Web site where you get information on the actors in the film. This is ideal for people who are reluctant to use PCs but are interested in the Internet.

WebTV was the first company which brought Internet services to viewers through a set-top computer box. Another option is WorldGate's technology, which offers the Internet through cable TV.

- 3 Virtual reality lets people interact with artificial objects and environments through three-dimensional computer simulation. In a VR system, you are hooked to a computer through a controlling device, such as a glove, and head-mounted displays give you the feeling of being propelled into an artificial three-dimensional world. The computer brings to life events in a distant, virtual world using databases or real-time objects and sounds. Your senses are immersed in an illusionary, yet sensate, world.

VR can be applied to anything from video games, testing a motor vehicle, visiting a virtual exhibition, to checking out imaginary kitchen designs.

- 4 Bluetooth is a standard wireless technology designed to connect mobile phones, computers and other devices, replacing direct cable links. Since it uses high frequency radio waves, the transfer of data and voice is very fast. All data are protected by advanced methods of encryption and authentication.

Bluetooth was initiated by Ericsson and the objective was to eliminate cables between mobile phones, PC cards, headsets, etc. Today it is supported by companies such as Nokia, IBM, Toshiba and Intel.

With Bluetooth, a handheld computer can be used to surf the Internet wherever you are, or to transfer files with other participants in meetings. Mobile phones will soon be used to control all sorts of gadgets in the house, from TV-sets to refrigerators.

Questions

- 1 Thanks to the the Wireless Application Protocol, can display Internet information.
- 2 transmit a caller's picture and voice simultaneously.
- 3 Internet services are brought to TV viewers through a box.

4 allows people interact with artificial objects and environments.

5 is designed to connect mobile phones, computers and other devices.

6 Bluetooth's objective was between mobile phones, PC cards, headsets.

B Match the terms on the left with the explanations on the right.

1 Internet-enabled TV a location on the Internet where a company puts web pages.

2 Website b technology that allows users to see a computer simulated world in which they can move

3 virtual reality c TV set used as an Internet device

4 WAP d device that handle multiple data types including voice and video

5 wireless e protocol that enables mobile phones to access Internet information

6 3G mobile phone f without the use of cables

C Read the extract from the interview and fill in the missing words. The first letter of each missing word is given.

Interviewer: Some portable computers are referred to as laptops, and others as (1)

p.....

Can you explain the difference?

Tom: Sure. Laptops are simply smaller versions of desktop PCs, but they can run similar Applications. However, palmtops are (2) h..... computer and weigh less than 2 pounds; They're used as PC companions or as personal (3) d..... assistants.

Interviewer: And what are the basic features of palmtops?

Tom: Well, these handheld devices run on rechargeable alkaline batteries, and have small (4) k..... and high-contrast LCD (5) s..... Sometimes, they have buttons for launching applications and a stylus or (6) p..... which is used for interacting with a touch-sensitive screen.

Interviewer: Do they need specialized operating (7) s.....?

Tom: Yes. They usually run Palm OS from Palm Computing or Pocket PC OS, the system developed by Microsoft for mobile-computing devices. Some pen-based systems can also (8) r..... handwritten characters and convert them into editable text.

Interviewer; Right. What sort of things can you do with handheld computes?

Tom: They're usually designed to store personal (9) i..... They have, for example, a calendar, an address book, a note pad, a calculator, and a voice recorder. They may also come with a built-in (10) m..... and Internet software which lets you send and receive e-mail from a payphone, a hotel or even a plane.

D Decide if the following sentences are true (T) or false (F).

- 1 Palmtops are a type of handheld computers.
- 2 Palmtops have a mouse and a keyboard as input devices.
- 3 Handheld computers run Windows XP.
- 4 Some pen computers come with operating system that can recognize handwriting.
- 5 Handhelds are primarily designed to organize and communicate personal information.
- 6 You cannot transmit data from handheld computers to desktop PCs and peripherals.
- 7 Business people will make up a large section of the handheld market.

E How do you say these expressions in your language?

- | | | | |
|---|-------------------------|---|------------------------------|
| 1 | rechargeable batteries | 5 | a Personal Digital Assistant |
| 2 | a flat LCD screen | 6 | an infra-red port |
| 3 | a pen-based interface | 7 | a portable suppliment |
| 4 | handwriting recognition | | |

F Translate into English.

- 1 Vào năm 2030 sức lao động của con người trong ngành công nghiệp sẽ được rô-bốt thay thế.
.....
- 2 Các gia đình sẽ có rô-bốt để làm công việc nhà.
.....
- 3 Vào cuối thế kỷ tới mỗi học sinh ở các trường học trên thế giới sẽ có máy tính cá nhân.
.....

4 Tiền mặt sẽ biến mất.

.....

The end

Unit 13 Spreadsheet

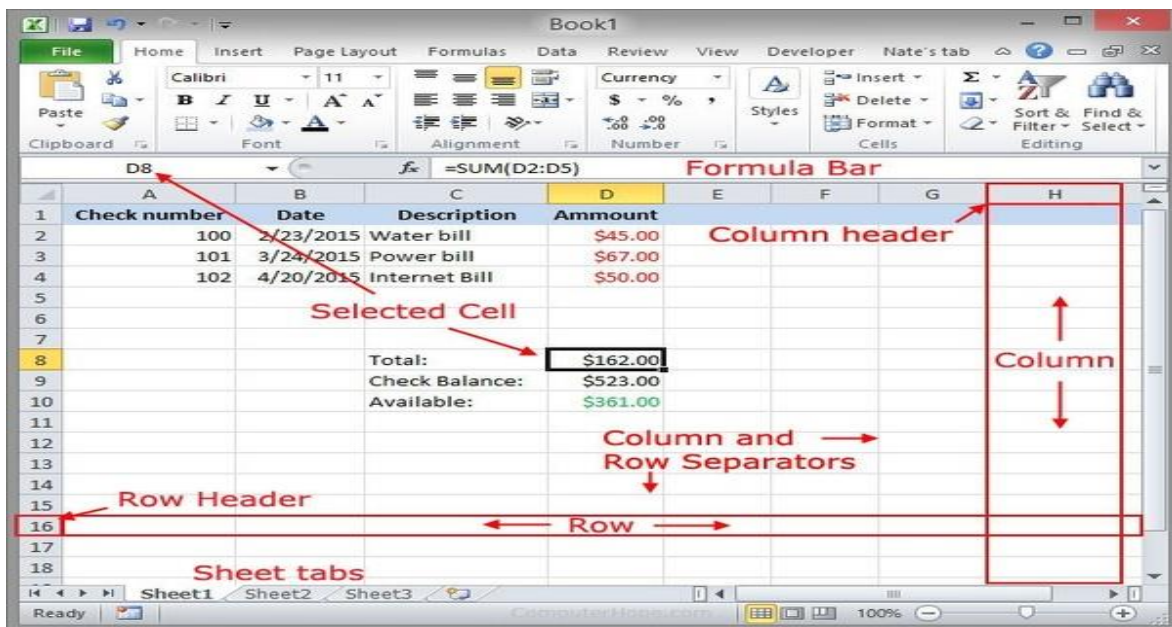

A Choose the right answer for these questions.

Questions

- 1 What is a spreadsheet?
- 2 What is the spreadsheet used for?
- 3 What type of information can be keyed into a cell?
- 4 What will happen if you change the data in the cell?

Answers

- a) You can enter three types of data in cells: labels, values, and formulas.
- b) A computer application program that shows accounting or other data in rows and columns; It is also a computer [application program](#) that simulates a physical spreadsheet by capturing, displaying, and manipulating [data](#) arranged in rows and columns.
- c) When you change the data in the cell, the value of the cell will change.
- d) It is used for storing and retrieving numerical data in the grid format for row and columns, entering, calculating and analyzing company data such as sales figures, sales taxes or commissions.

B Choose the right word from the box and write them on the lines.

values	formulas	labels
text	a cell	functions

- 1 (text) are descriptive pieces of information, such as names, months, or other identifying statistics, and they usually include alphabetic characters.
- 2 (numbers) are generally raw numbers or dates.
- 3 are instructions for Excel to perform calculations.
- 4 is the intersection of a row and a column.
- 5 Letters, numbers and dates are considered as
- 6 Any information you enter into a spreadsheet will be stored in a cell. Each cell can contain different types of content, including text, formatting, formulas, and

C Translate these steps into your own language.

To insert content:

1. Click a **cell** to select it.

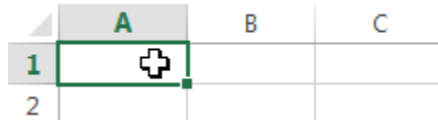

2. Type **content** into the selected cell, then press **Enter** on your keyboard. The content will appear in the **cell** and the **formula bar**. You can also input and edit cell content in the formula bar.

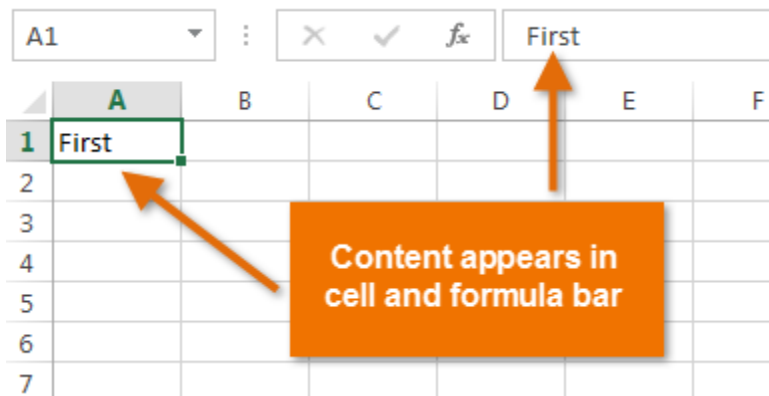

To delete cell content:

1. Select the **cell** with content you want to delete.

	A	B	C
1			
2	First Name	Middle Name	Last Name
3	Heidi	Lauren	Lee
4	Josie	Marie	Gates
5	Wendy	Anne	Crocker
6	Loretta	Susan	Johnson

2. Press the **Delete** or **Backspace** key on your keyboard. The cell's contents will be deleted.

	A	B	C
1			
2	First Name	Middle Name	Last Name
3	Heidi		Lee
4	Josie	Marie	Gates
5	Wendy	Anne	Crocker
6	Loretta	Susan	Johnson

To delete cells:

There is an important difference between **deleting the content of a cell** and **deleting the cell itself**. If you delete the entire cell, the cells below it will **shift up** and replace the deleted cells.

1. Select the **cell(s)** you want to delete.

	A	B	C
1			
2	First Name	Middle Name	Last Name
3	Heidi	Joy	Lee
4	Josie	Marie	Gates
5	Wendy	Anne	Crocker
6	Loretta	Susan	Johnson

2. Select the **Delete** command from the **Home** tab on the **Ribbon**.

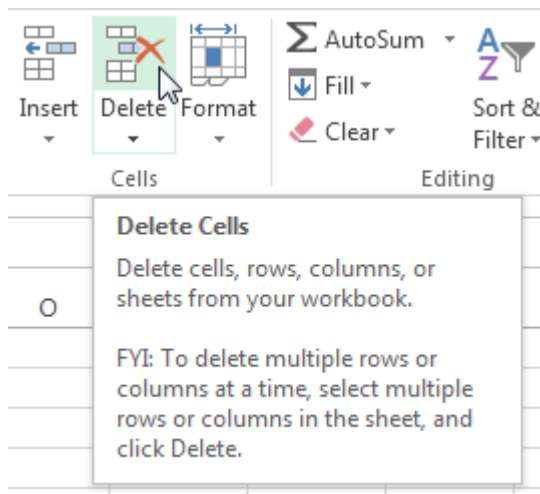

3. The cells below will **shift up**.

	A	B	C
1	First Name	Middle Name	Last Name
2	Heidi	Joy	Lee
3	Josie	Marie	Gates
4	Wendy	Anne	Crocker
5	Loretta	Susan	Johnson

To copy and paste cell content:

Excel allows you to **copy** content that is already entered into your spreadsheet and **paste** that content to other cells, which can save you time and effort.

1. Select the **cell(s)** you want to **copy**.

D	E
Friday, March 01, 2013	Friday, March 08, 2013
x	

2. Click the **Copy** command on the **Home** tab, or press **Ctrl+C** on your keyboard.

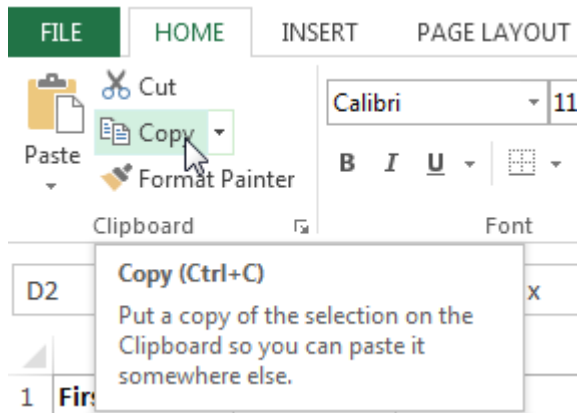

3. Select the **cell(s)** where you want to **paste** the content. The copied cells will now have a **dashed box** around them.

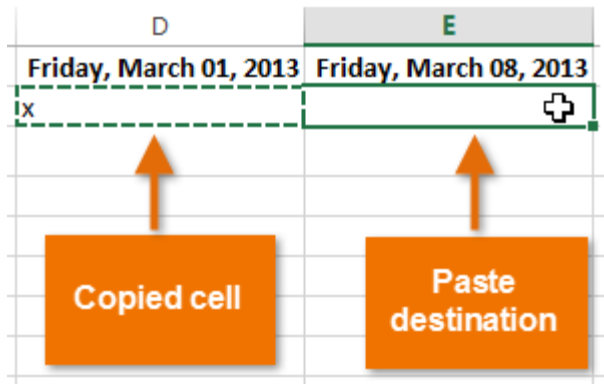

4. Click the **Paste** command on the **Home** tab, or press **Ctrl+V** on your keyboard.

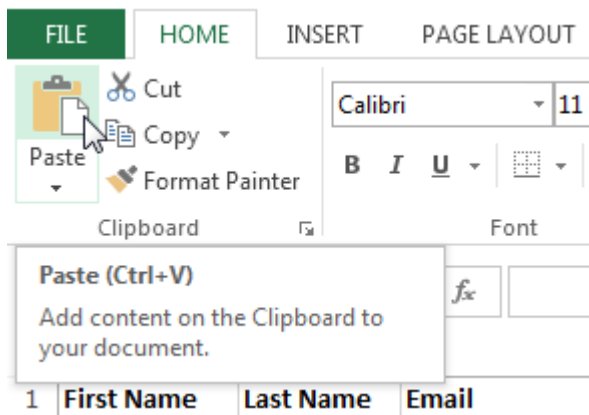

5. The content will be **past**ed into the selected cells.

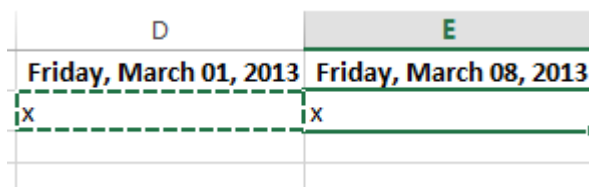

To cut and paste cell content:

Unlike copying and pasting, which **duplicate**s cell content, **cutting** allows you to **move** content between cells.

1. Select the **cell(s)** you want to **cut**.

D	E
Friday, March 01, 2013	Friday, March 08, 2013
x	x
	x
	x
	x

2. Click the **Cut** command on the **Home** tab, or press **Ctrl+X** on your keyboard.

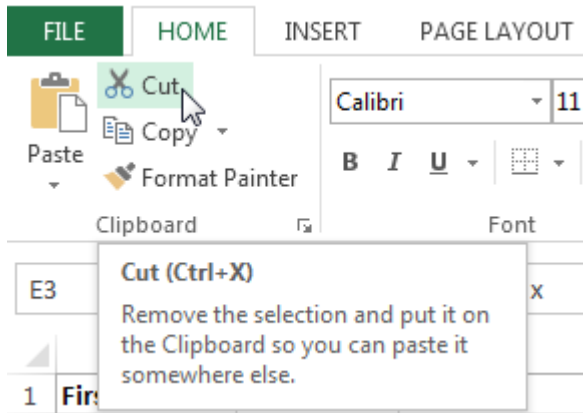

3. Select the cells where you want to **paste** the content. The cut cells will now have a **dashed box** around them.

D	E
Friday, March 01, 2013	Friday, March 08, 2013
x	x
	x
	x
	x

Paste destination
Cut Cells

4. Click the **Paste** command on the **Home** tab, or press **Ctrl+V** on your keyboard.

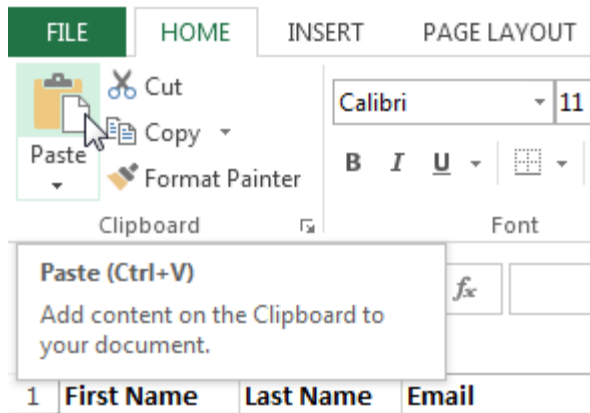

5. The cut content will be **removed** from the original cells and **pasted** into the selected cells.

D	E
Friday, March 01, 2013	Friday, March 08, 2013
x	x
x	
x	
x	

D Translate into English.

- 1 Một chương trình bảng tính hiển thị thông tin dưới hình thức bảng với nhiều cột và hàng.
- 2 Trong một bảng tính bạn có thể nhập các con số và các công thức.
- 3 Trong một bảng tính bạn có thể thay đổi độ rộng của cột.
- 4 Các bảng tính có thể được dùng như các cơ sở dữ liệu.